



# Current Tools

FOR THE PROFESSIONAL ELECTRICIAN

## Current Tools™ 77 Series Electric Bender

for bending 1/2" thru 2" RIGID - EMT - IMC  
and 40 mil PVC coated RIGID Conduit

*for units with serial number beginning with "T" or "W"*

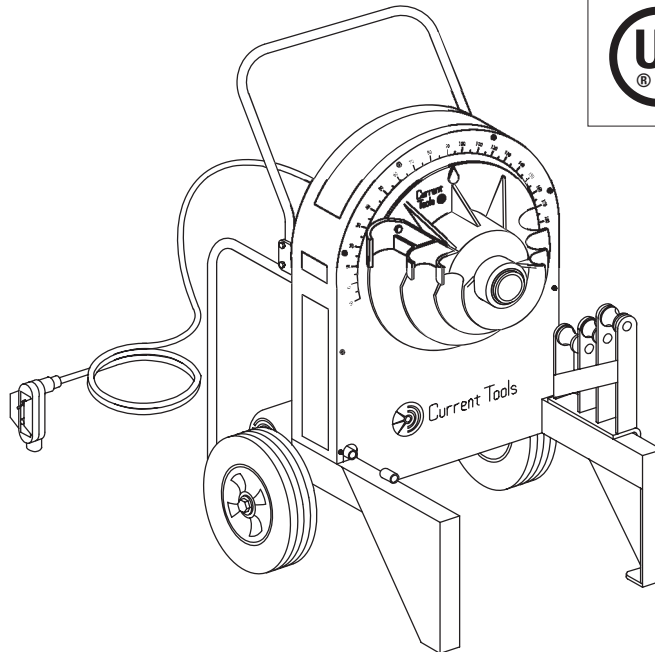

**LISTED**  
CONDUIT BENDER  
91FF  
- Chick Springs -



## Operating, Maintenance, Safety, and Parts Manual

12/07 REV. 6



Read and understand this material before operating or servicing this bender. Failure to understand how to safely operate and service this unit could result in serious injury or death.

This manual is free of charge. All personnel who operate this Bender should have a copy of this manual and read and understand its contents. To request a copy, call or write to the address below.

[www.TradeToolSupply.com](http://www.TradeToolSupply.com)

503.221.8665

Sales and Rentals



# TRADE TOOL



## TABLE OF CONTENTS

<b><i>Safety Alerts</i></b> .....	<b>3</b>
<b><i>Important Safety Information</i></b> .....	<b>4, 5</b>
<b><i>Specifications – 77 Series Electric Bender</i></b> .....	<b>6</b>
<b><i>Model Descriptions</i></b> .....	<b>6</b>
<b><i>Features</i></b> .....	<b>6, 7</b>
<b><i>Shoe Groups</i></b> .....	<b>8</b>
<b><i>Conduit Centerline Bending Radii</i></b> .....	<b>8</b>
<b><i>Grounding Instructions</i></b> .....	<b>9</b>
<b><i>Mounting Bending Shoes</i></b> .....	<b>10</b>
<b><i>Mounting Support Rollers &amp; Support Units</i></b> .....	<b>11</b>
<b><i>Mounting Instructions for Greenlee® Shoes &amp; Attachments</i></b> ...	<b>11</b>
<b><i>General Bending Instructions</i></b> .....	<b>12, 13</b>
<b><i>Bending Instructions for</i></b> <b><i>1 1/2" and 2" EMT &amp; IMC Conduit</i></b> .....	<b>14 - 16</b>
<b><i>Squeeze Adjustment Procedure for</i></b> <b><i>1 1/2" and 2" EMT &amp; IMC Support Roller Units</i></b> .....	<b>17</b>
<b><i>Maintenance</i></b> .....	<b>18, 19</b>
<b><i>Stub-Up Bending Information and Charts</i></b> .....	<b>20, 21</b>
<b><i>Offset Bending Information and Charts</i></b> .....	<b>22, 23</b>
<b><i>Troubleshooting</i></b> .....	<b>24</b>
<b><i>Exploded Views</i></b> .....	<b>25, 26</b>
<b><i>Parts List</i></b> .....	<b>27, 28</b>
<b><i>Electrical System Diagram</i></b> .....	<b>29</b>
<b><i>Parts List – Bending Shoes &amp; Roller Supports</i></b> .....	<b>30 - 34</b>
<b><i>Exploded View – Roller Support Unit</i></b> .....	<b>35</b>
<b><i>Parts List – Roller Support Unit - EMT</i></b> .....	<b>36</b>
<b><i>Parts List – Roller Support Unit - IMC</i></b> .....	<b>37</b>



## Safety Alert Symbol

THIS SAFETY SYMBOL is used to call your attention to instructions that concern your personal safety. It means: ATTENTION! BE AWARE! THIS IS AN IMPORTANT SAFETY INSTRUCTION!

Read, understand, and follow these safety instructions. Failure to follow these safety instructions may result in injury or death.

### **DANGER**

Immediate hazards which, if not avoided, WILL result in serious personal injury or death.

### **WARNING**

Hazards or unsafe practices which, if not avoided, COULD result in serious personal injury or death.

### **CAUTION**

Hazards or unsafe practices which, if not avoided, COULD result in minor personal injury or property damage.

## RETAIN SAFETY INFORMATION



This manual should be read and understood by all personnel who operate and service this bender. Failure to understand how to safely operate and service this unit could result in injury or death. This unit should only be operated and serviced by qualified personnel.



## IMPORTANT SAFETY INFORMATION

Follow **ALL** safety information provided by the manufacturer.

- ⚠ DANGER** NEVER operate the bender in an explosive atmosphere.
- ⚠ WARNING** NEVER operate the bender in wet or damp locations. Do NOT expose the bender to rain.
- ⚠ WARNING** ALWAYS use 120 VAC, 20 AMP ground fault protected receptacle for power supply that is properly installed and meets all applicable electrical codes. See grounding instructions on page 3.
- ⚠ WARNING** ALWAYS inspect power cord before using bender. Replace damaged or worn cords.
- ⚠ WARNING** ALWAYS disconnect bender before servicing.
- ⚠ WARNING** ALWAYS make sure switch is in the off position before plugging in. This will reduce the risk of unintentional starting.
- ⚠ WARNING** Do NOT modify the plug provided with the bender.
- ⚠ WARNING** ALWAYS use 12-gauge extension cords that have three prong grounding type plugs and three-hole receptacles that accept the bender's plug. Do NOT use an adapter.
- ⚠ WARNING** NEVER use an extension cord longer than 100 feet.
- ⚠ WARNING** ALWAYS replace damaged extension cords.
- ⚠ WARNING** ALWAYS disconnect the bender before servicing or changing shoes, attachments or supports, and when not in use.
- ⚠ WARNING** ALWAYS inspect the bender before operating. Replace any damaged, missing or worn parts.
- ⚠ WARNING** NEVER alter this equipment. Doing so will void this warranty.
- ⚠ WARNING** NEVER remove guards, they are installed for your protection.
- ⚠ WARNING** ALWAYS check for damaged or worn parts. Before further use of the tool a guard or other part that is damaged should be carefully checked to determine that it will operate properly and perform its intended function. Check for alignment of moving parts, binding of moving parts, breakage of parts, mounting and any other conditions that may affect its operation. A guard or other part that is damaged should be properly repaired or replaced.

## IMPORTANT SAFETY INFORMATION *continued . . .*

**▲ WARNING**

ALWAYS use recommended accessories. Consult this manual for recommended accessories. The use of improper accessories may cause risk of injury.

**▲ WARNING**

ALWAYS keep hands and feet away from pinch points such as bending shoes, rollers and conduit when bender is in use.

**▲ WARNING**

Operator must ALWAYS face the front of the bender with the bending degree scale visible and maintain a minimum of 3 feet distance while the conduit is being bent. All other personnel must remain out of the area while the bender is in operation.

**▲ WARNING**

ALWAYS use appropriate shoe groove and roller support for the type and size conduit to be bent.

**▲ WARNING**

If bending shoe will not turn, STOP unit and unplug before checking for any obstructions.

**▲ WARNING**

Do NOT use bender or attachment to do a job for which it was not designed.

**▲ WARNING**

ALWAYS keep conduit under control when unloading.

**▲ WARNING**

ALWAYS keep the path of the bending conduit clear of obstructions. Make sure all obstacles are clear of the bending path BEFORE you bend the conduit.

**▲ WARNING**

Be sure handle is bolted securely to the bender frame before moving or lifting the bender.

**▲ WARNING**

NEVER stand on bender. Serious injury could occur if the bender is tipped or if the bending shoe is unintentionally contacted.

**▲ WARNING**

ALWAYS wear approved safety glasses when the bender is in operation.

**▲ WARNING**

ALWAYS wear proper apparel. Do not wear loose clothing, gloves, neckties, rings, bracelets, or other jewelry which may get caught in moving parts. Non-slip footwear is recommended. Wear protective hair covering to contain long hair.

**▲ WARNING**

ALWAYS keep children away. All visitors should be kept a safe distance from work area.

**▲ WARNING**

ALWAYS make bender childproof with lockouts, master switches or by unplugging unit.

**▲ CAUTION**

The bender and some accessories exceed 50 lbs. and will require more than one person to lift, transport and assemble.

**▲ CAUTION**

Only use the bender for its intended purpose as specified in this manual.

**▲ CAUTION**

ALWAYS use this bender in a dry, well lighted area.

**▲ CAUTION**

ALWAYS maintain bender with care. Keep bender clean for best and safest performance.

## SPECIFICATIONS – 77 SERIES ELECTRIC BENDER

1/2" thru 2" RIGID conduit  
 1/2" thru 2" EMT conduit  
 1/2" thru 2" IMC conduit  
 1/2" thru 2" 40 mil PVC coated RIGID conduit  
 1/2" thru 2" schedule 40 steel pipe

No modification to the 77 POWER UNIT is required to accommodate these shoes or rollers.  
 No tools are required to install or remove these shoes and roller supports.

The 77 Series Electric Bender is NOT to be used for bending any conduit or pipe wall thickness above schedule 40 pipe.

width	29 1/2"
length	24 3/4"
height	39"
weight	256 lbs. Power Unit Only - without shoes

## MODEL DESCRIPTIONS

77	Electric Bender Power Unit only, without shoes and roller supports
77-RIG	Electric Bender with shoes and roller supports for 1/2" thru 2" RIGID conduit and schedule 40 pipe and 1/2" thru 1 1/4" IMC conduit
77-EMT	Electric Bender with shoes and roller supports for 1/2" thru 2" EMT conduit
77-IMC	Electric Bender with shoes and roller supports for 1 1/2" and 2" IMC conduit
77-PVC	Electric Bender with shoes and roller supports for 1/2" thru 2" PVC coated RIGID conduit

## FEATURES

1. **Bending Degree Scale** - easy to read for exact bends.
2. **Support Rollers** - for supporting the conduit during bending.
3. **Hinge Pin** - for securing the support rollers.
4. **12 inch Wheels** - for easy mobility.
5. **D.C. Motor** - quiet and strong.
6. **Bending Instructions Decal** - easy to read for quick reference.
7. **Remote Pendant** - with 6 foot cord. ( Bend and unload from pendant. )
8. **Removable Handle** - may be removed or may be pivoted for dog-leg bends
9. **Back Rails** - Protect the back of bender and enable the bender to be used horizontally

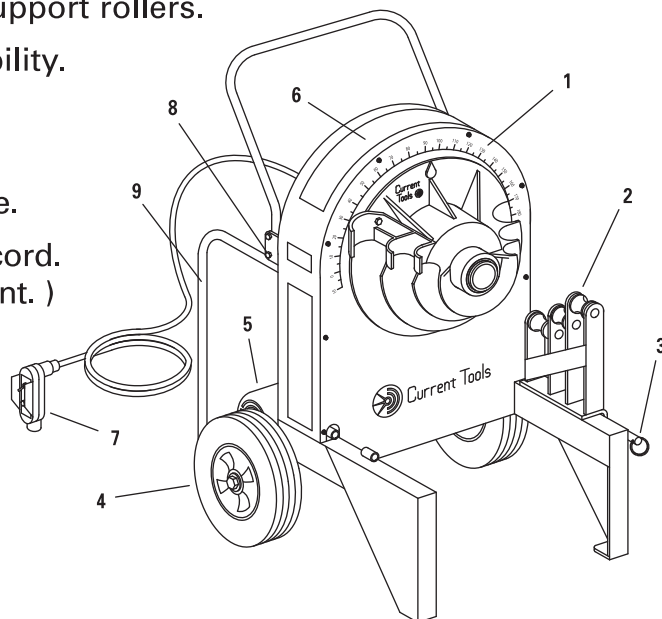

## Special Features

*The 77 Series Electric Benders have a unique feature to pivot or remove the handles during a "Dog-Leg Bend." See Figure 1 below.*

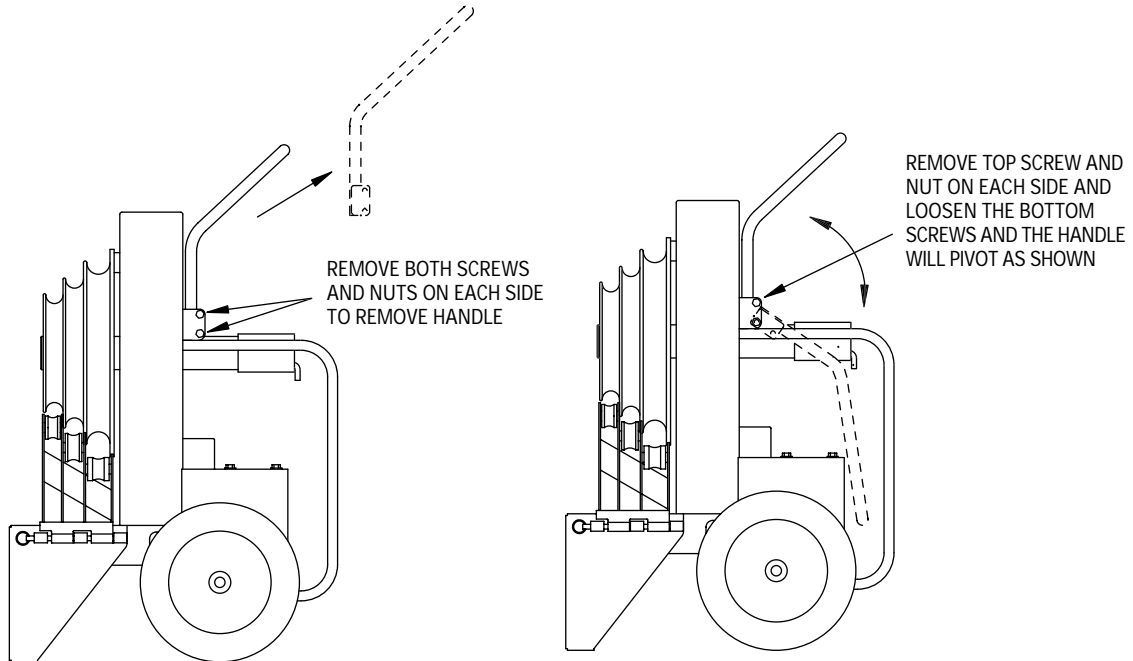

Figure 1

## **WARNING**

When replacing handle, be sure to replace screws and nuts and also to tighten securely before moving or transporting.

*The 77 Series Electric Benders may also be used in a horizontal position. The bender can operate in this position as efficiently as it does in the upright position. See Figure 2 below.*

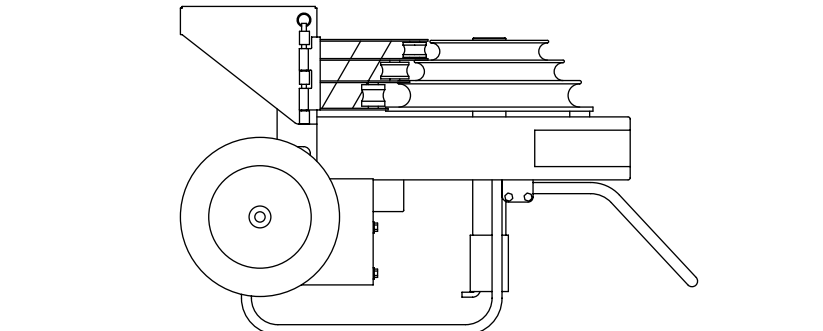
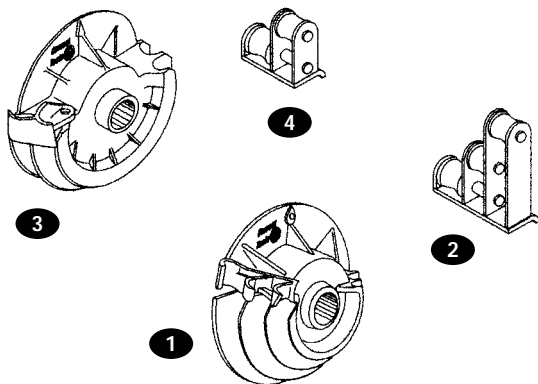

Figure 2

# SHOE GROUPS

## RIGID



**700 R** - for bending 1/2" thru 2" RIGID conduit, 1/2" thru 1 1/4" IMC conduit and 1/2" thru 2" schedule 40 pipe includes the following four items.

Key	Catalog	Description
1	2-1301	1/2" thru 1 1/4" bending shoe
2	2-1001	1/2" thru 1 1/4" roller support
3	2-1401	1 1/2" and 2" bending shoe
4	2-1002	1 1/2" and 2" roller support

## IMC

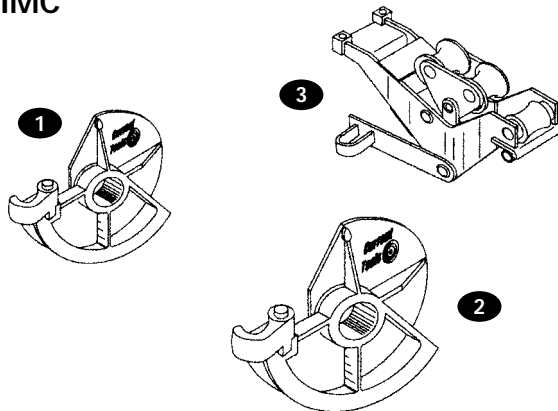

**700 I** - for bending 1/2" and 2" IMC includes the following four items.

Key	Catalog	Description
1	2-1801	1 1/2" bending shoe
2	2-1901	2" bending shoe
3	2-1200	1 1/2" thru 2" IMC roller support unit
	8-0501	metal storage box ( not shown )

## EMT

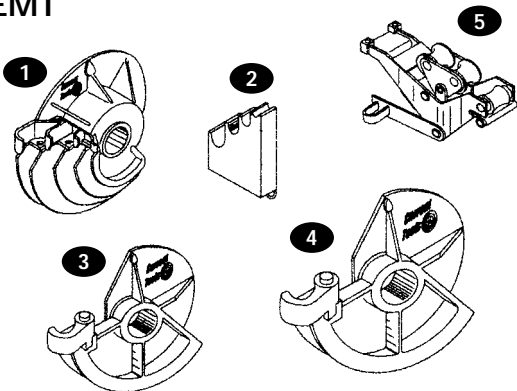

**700 E** - for bending 1/2" thru 2" EMT ( Thinwall ) includes the following six items.

Key	Catalog	Description
1	2-1501	1/2" thru 1 1/4" bending shoe
2	2-1003	1/2" thru 1 1/4" EMT support
3	2-1601	1 1/2" bending shoe
4	2-1701	2" bending shoe
5	2-1100	1 1/2" thru 2" EMT roller support
	8-0501	metal storage box ( not shown )

## PVC

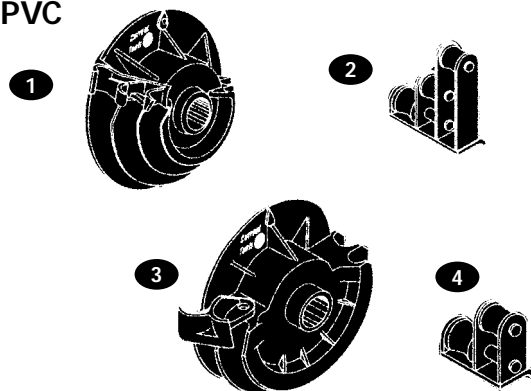

**700 P** - for bending 1/2" thru 2" 40 mil PVC coated RIGID includes the following five items.

Key	Catalog	Description
1	2-2001	1/2" thru 1 1/4" bending shoe
2	2-1004	1/2" thru 1 1/4" roller support
3	2-2101	1 1/2" and 2" bending shoe
4	2-1005	1 1/2" and 2" roller support
	8-0501	metal storage box ( not shown )

# CONDUIT CENTERLINE BENDING RADII

size	1/2"	3/4"	1"	1 1/4"	1 1/2"	2"
EMT	4 1/4"	5 3/8"	6 3/4"	8 3/4"	8 9/32"	9 3/16"
IMC	-	-	-	-	8 9/32"	9 3/16"
RIGID	4 3/8"	4 1/2"	5 3/4"	7 1/4"	8 1/4"	9 1/2"

## **WARNING**

**ELECTRIC SHOCK HAZARD!** Only connect the bender to a 20 AMP GFCI protected circuit. Do NOT modify the plug which is provided with the unit. Failure to follow these warnings can result in serious injury or death.

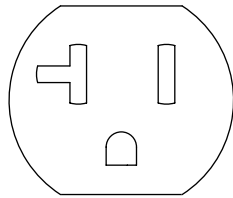

RECEPTACLE

*Figure 3*

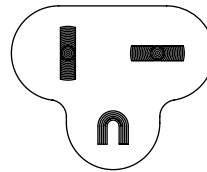

PLUG

*Figure 4*

In the event of a malfunction or breakdown, grounding provides a path of least resistance for electric current to reduce the risk of electric shock. The bender is equipped with an electric cord having an equipment grounding conductor and a grounding plug. Only connect the bender to a 20 AMP GFCI protected receptacle which is properly installed and grounded to meet all applicable electrical codes. Do NOT use an adapter.

Do NOT modify the plug provided. If it will not fit the receptacle, have the proper receptacle installed by a qualified electrician.

Improper connection of the equipment grounding conductor can result in risk of electric shock. The conductor with insulation having an outer surface that is green with or without yellow stripes is the equipment grounding conductor. If repair or replacement of the electric cord or plug is necessary, do not connect the equipment grounding conductor to a live terminal.

Check with a qualified electrician or service personnel if the grounding instructions are not completely understood, or if in doubt as to whether the bender is properly grounded.

Use only 3-wire extension cords that have 3-prong grounding plugs and 3-pole receptacles that accept the bender's plug.

Repair or replace damaged or worn cord immediately.

This bender is intended for use on a circuit that has a receptacle that looks like the one illustrated in Figure 3 above. The bender has a grounding plug that looks like the plug illustrated in Figure 4 above.



## MOUNTING BENDING SHOES

Choose desired shoe size and type ( RIGID, IMC, EMT, or 40 mil PVC coated RIGID ) and slide shoe onto the main drive sprocket shaft. See Figure 5 below.

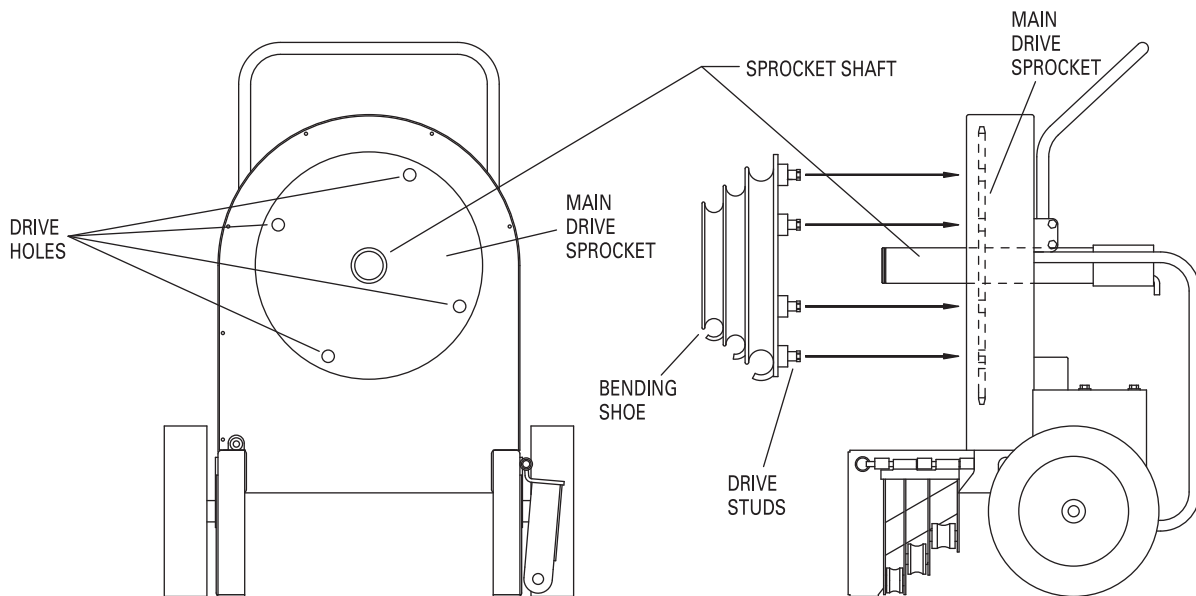

*Figure 5*

*Figure 6*

Next, align the four drive studs on the back of the shoe with the four drive holes in the main drive sprocket.

Push the shoe onto the main drive sprocket shaft. See Figure 6.



## MOUNTING SUPPORT ROLLERS & SUPPORT UNITS

Choose the desired support unit for corresponding shoe size and type ( RIGID, IMC, EMT, or 40 mil PVC coated RIGID ). The appropriate size and type of support unit **MUST** be used with the corresponding shoe size and type.

Mount the support unit on the right leg of the bender as you face the unit. Secure the support unit with the quick release hinge pin. See Figure 7.

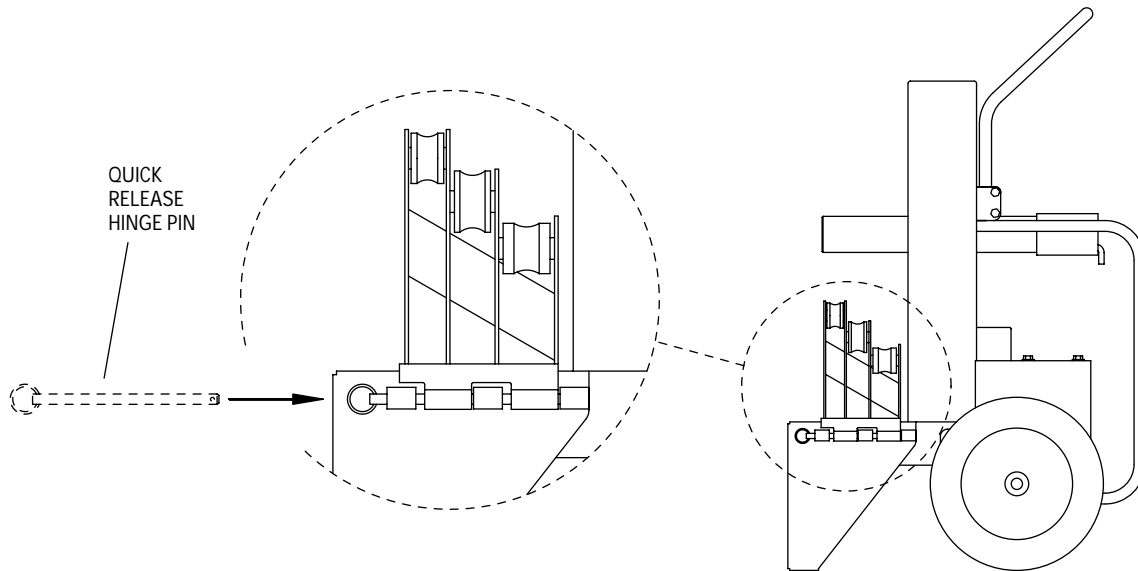

Figure 7



## MOUNTING INSTRUCTIONS FOR GREENLEE® SHOES AND ATTACHMENTS

Bending shoes and attachment from Greenlee® 555® and 555 Classic® R, E, I ( RIGID, EMT, IMC ) and 40 mil PVC coated RIGID benders with serial number PL and AAJ will fit the 77 bender. All 77 bending shoes and attachments will fit Greenlee® 555® R, E, I benders with PL and AAJ serial numbers.

\* Greenlee® 555® and 555 Classic® are registered trademarks of Greenlee/Textron.

## GENERAL BENDING INSTRUCTIONS

# ⚠ DANGER

**NEVER** operate this bender in an explosive atmosphere. Injury or Death may occur.

Bending instructions for:

- 1/2" thru 2" RIGID conduit
- 1/2" thru 1 1/4" EMT conduit
- 1/2" thru 1 1/4" IMC conduit
- 1/2" thru 2" 40 mil PVC coated RIGID conduit
- 1/2" thru 2" schedule 40 pipe

See pages 10 and 11 for mounting shoes and support units.  
Be sure to match the appropriate shoe with its corresponding support unit.

1. Mark pipe/conduit to desired length. Note that a minimum of 2" from the end of the conduit to the front edge of the hook is required to eliminate flattening the end of the pipe/conduit. See Figure 8a.

NOTE: Stub-up and Offset Dimensions can be found on the Bending Charts on pages 20 thru 23 of this manual or on the bending instructions decal on top of each bender.

2. Rotate the bending shoe 5 to 10 degrees below the 0 ( zero ) degree setting, as shown in Figure 8b below.

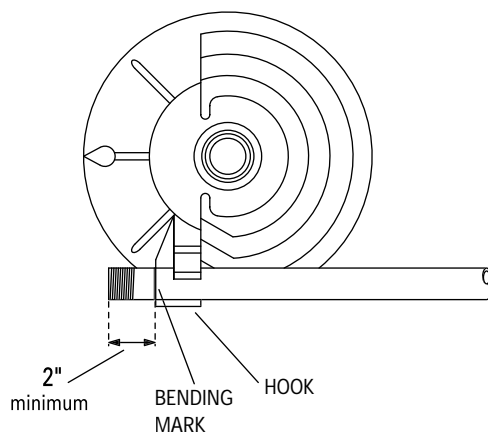

PLACE BENDING MARK IN LINE  
WITH FRONT (OUTSIDE) EDGE OF HOOK

Figure 8a

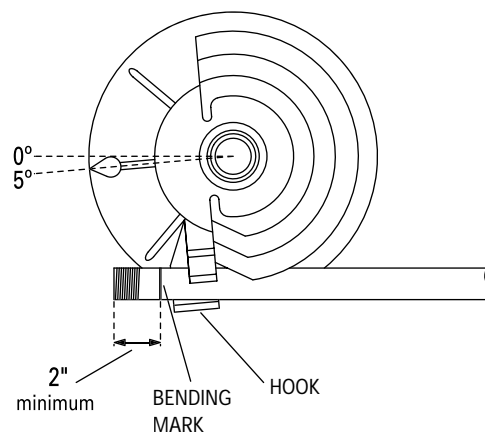

Figure 8b

## GENERAL BENDING INSTRUCTIONS *continued . . .*

3. After marking the pipe/conduit, place it into the bender. See Figure 8a. The pipe/conduit should slide over the correct size support unit, through the shoe groove and into the hook. The bending mark should be at the front ( OUTSIDE ) edge of the hook. See Figure 8a.
4. Using the remote hand unit ( pendant ), place the "Bend/Unload" switch in the "bend" position. Press the "Jog" button and advance the bender. Be sure to check the alignment of the bending mark as the rotating shoe locks the pipe/conduit into position. Advance the bender shoe to desired degree of bend. When the pointer on the shoe reaches the desired degree of bend, release the "Jog" button and the bender will stop. See Figure 9.

NOTE: Due to springback in pipe/conduit, some over bending is necessary to achieve the desired degree of bend. See page 21 or the bending instruction decal on top of each bender for approximate springback compensation figures.

5. To release the pipe/conduit, place the "Bend/Unload" switch in the "Unload" position. Press the "Jog" button and reverse the shoe far enough to release the conduit. Then, rotate the support unit out of the way. See Figure 9. The pipe/conduit can now be removed.

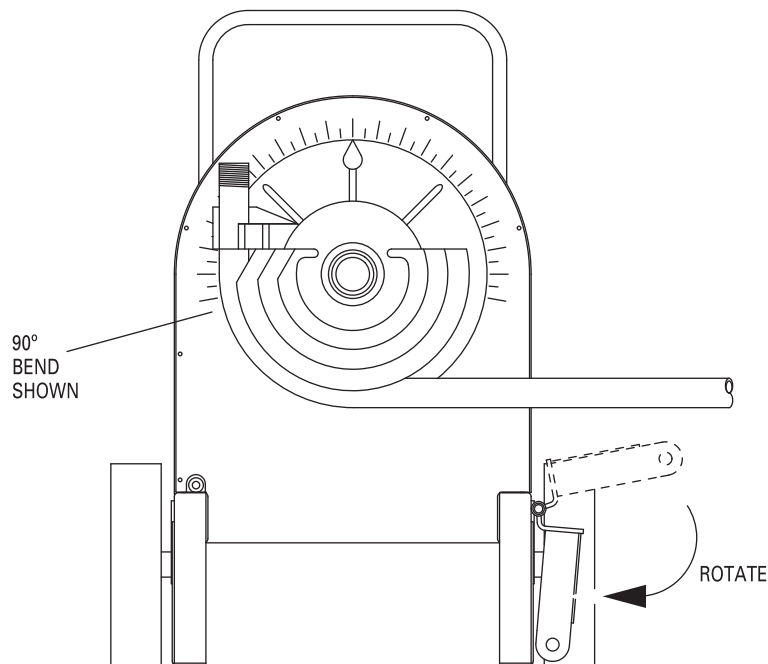

Figure 9



### WARNING

The pipe/conduit should be under control when unloading.  
Failure to do this may result in injury or death.



## BENDING INSTRUCTIONS FOR 1 1/2" AND 2" EMT & IMC CONDUIT

1. See pages 10 and 11 for mounting shoes and support units. Be sure to match the appropriate shoe with its corresponding support unit.

NOTE: The outside roller on the 1 1/2" thru 2" IMC support unit is steel. See Figure 10. The outside roller on the 1 1/2" thru 2" EMT support unit is urethane. See Figure 11.

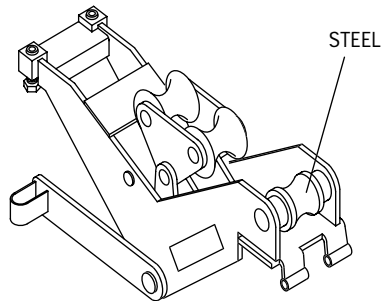

IMC SUPPORT UNIT

Figure 10

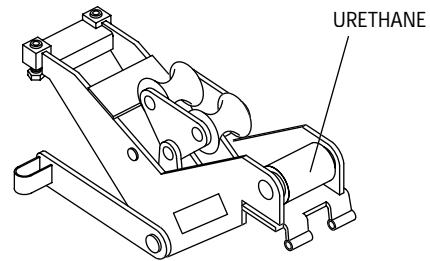

EMT SUPPORT UNIT

Figure 11

2. Mark the conduit to the desired length. Note that a 2" minimum dimension is required to eliminate flattening the end of the conduit. See Figure 12.

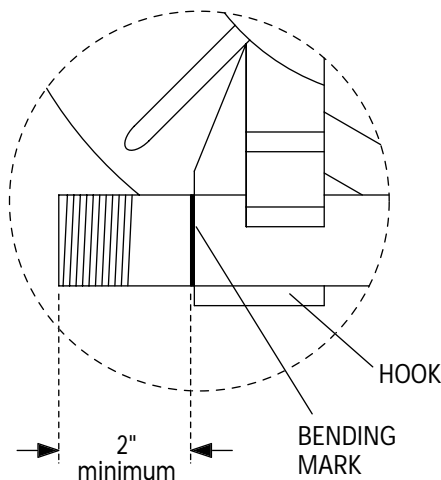

Figure 12

NOTE: "Stub-up" and "Offset" dimensions can be found on the bending charts on pages 20 thru 23 of this manual or on the bending instruction decal located on the top of each bender.

## BENDING INSTRUCTIONS FOR 1 1/2" AND 2" EMT & IMC CONDUIT *continued . . .*

3. Rotate the bending shoe 5 to 10 degrees below the degree setting. See Figure 8b.
4. After marking the conduit, place it into the bender. The conduit should slide over the support rollers and through the shoe groove and into the hook. The bending mark should be at the front ( OUTSIDE ) edge of the hook. See Figure 12.

NOTE: The appropriate size and type of support unit MUST be used with the corresponding shoe size and type.

5. Step on the "Engaging Pedal" which will raise the rollers to come in contact with the conduit. See Figure 13. Be sure the correct rollers for the size conduit being bent are in position to engage the conduit.

NOTE: See SQUEEZE ADJUSTMENT PROCEDURE on page 17.

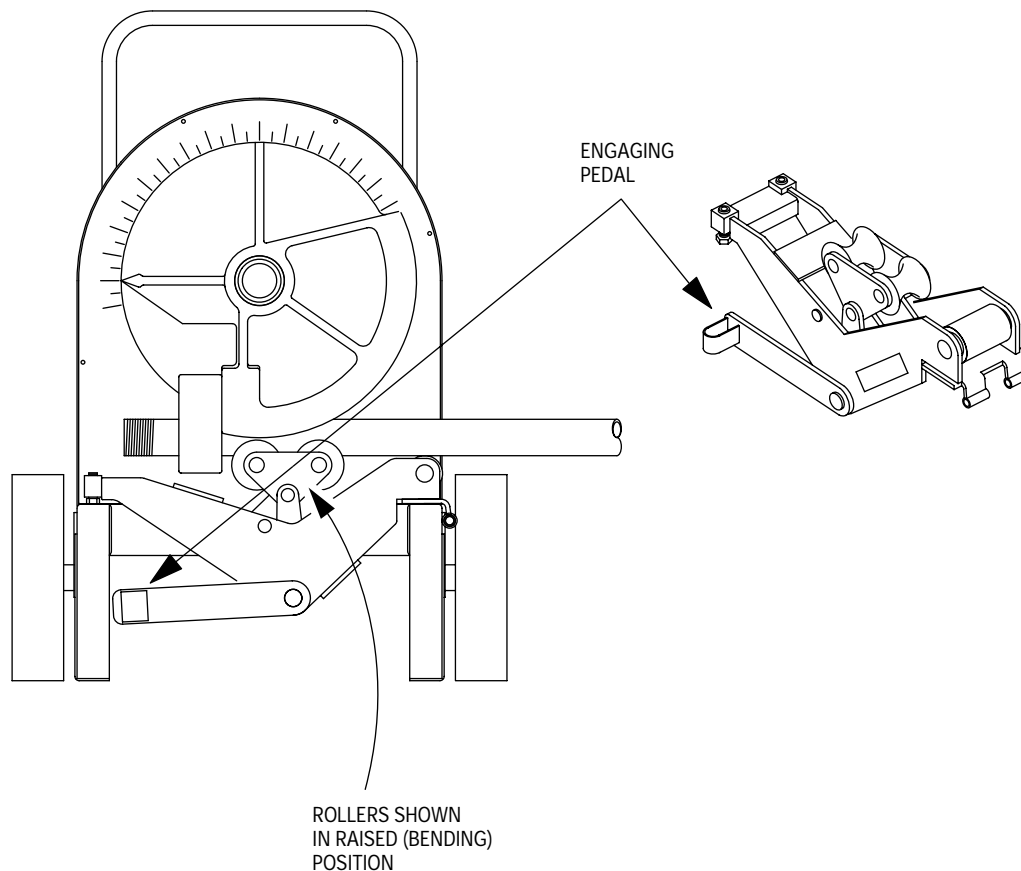

*Figure 13*

BENDING INSTRUCTIONS FOR  
1 1/2" AND 2" EMT & IMC CONDUIT *continued . . .*

6. Keep foot pressure on the engaging pedal and push the Bend/Unload switch to the *Bend* position. Then press the Jog button. The conduit will pull the support rollers against the stop. Foot pressure can then be removed from the engaging pedal. Be sure to check the alignment of the bending mark as the rotating shoe locks the conduit into position.

Advance the bender shoe to the desired degree of bend. When the pointer on the shoe reaches the desired degree of bend, release the Jog button and the bender will stop.

NOTE: Due to springback in pipe/conduit, some overbending is necessary to achieve the desired degree of bend. See page 21 or the bending instructions decal located on the top of each bender for approximate springback compensation figures.

NOTE: Do NOT allow the rollers to come in contact with the bending shoe. The shoe and rollers squeeze the conduit but they should never touch each other.

7. To release the conduit, place the Bend/Unload switch in the *Unload* position. Press the Jog button and reverse the shoe. The support rollers will then drop, allowing removal of the conduit.

 **WARNING**

The pipe/conduit should be under control when unloading.  
Failure to do this may result in injury or death.

8. After removal of the conduit, inspect it for wrinkling or excessive side marks. If these conditions occur, refer to the SQUEEZE ADJUSTMENT PROCEDURE. See page 17.



**TRADE TOOL**



## SQUEEZE ADJUSTMENT PROCEDURE FOR 1 1/2" AND 2" EMT & IMC SUPPORT ROLLER UNITS

The 77 bender has a Squeeze Adjustment feature if wrinkling or side marking becomes a problem during the bending process. This feature allows you to increase or decrease the amount of pressure applied to the conduit during bending, thereby eliminating these problems. Begin with the 1/2" starting location of the adjusting bolts as shown in Figure 14.

1. If wrinkling occurs, pressure against the conduit during the bending process must increase. To increase the squeeze ( pressure ), loosen both set screws and turn both adjusting bolts one-half turn clockwise. Tighten both set screws and bend one piece of conduit to test the adjustment. If wrinkling still occurs, repeat the procedure.

NOTE: Both adjusting bolts MUST be in contact with the bender frame. See Figure 15.

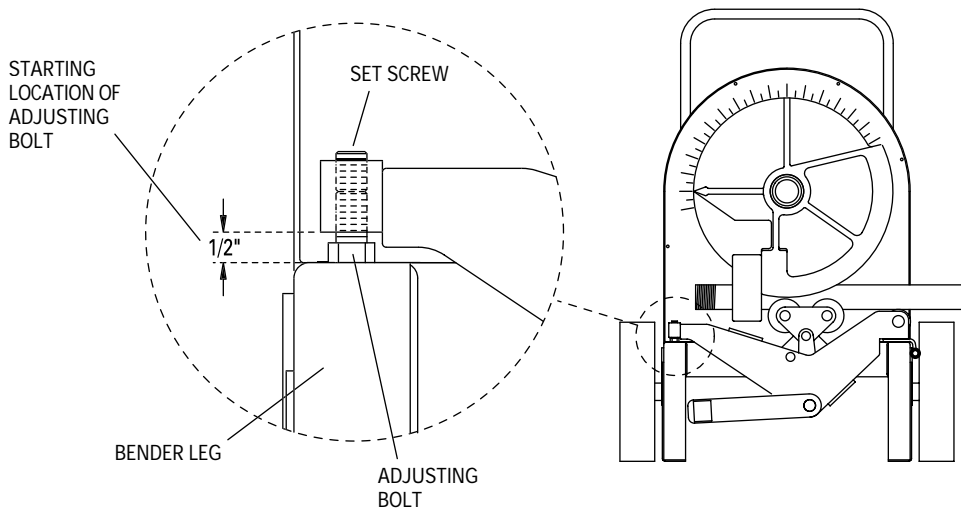

Figure 14

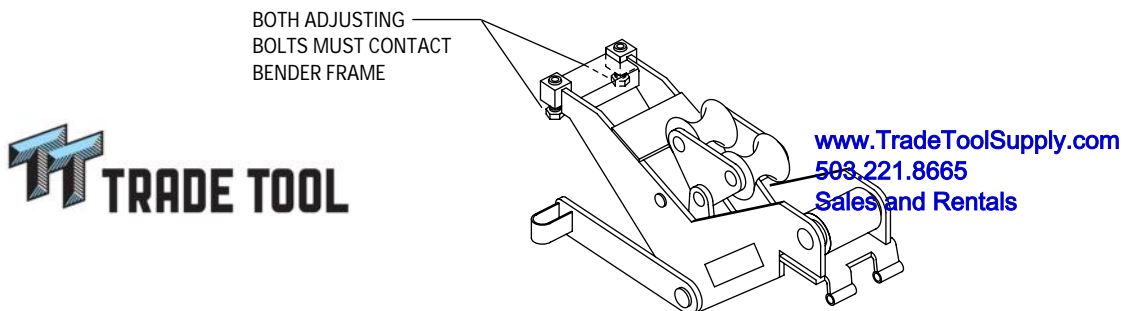

Figure 15

2. If side marking occurs, or loading IMC or EMT is a problem, pressure against the conduit during the bending process must be decreased. To decrease the squeeze ( pressure ), loosen both set screws and turn both adjusting bolts one-half turn counter-clockwise. Tighten both set screws and bend one piece of conduit to test the adjustment. If side marking still occurs, repeat the procedure.

NOTE: Both adjusting bolts MUST be in contact with the bender frame.

## WARNING

**ALWAYS** disconnect power supply before removing any guards or covers and before servicing this bender. Failure to do so may result in serious injury or death.

1. The Gear Box is filled with oil at the factory and should not require periodic flushing. If the Gear Box is opened for repair, flush by filling the unit with an AGMA #7 oil. Next, run the unit with no load for 3 minutes. Then, drain and refill the unit with 28 fluid ounces of an AGMA #7 oil such as the ones listed below.

Amoco – Amoco Worm Gear Oil

Chevron – Cylinder Oil 460X

Exxon – CYLESSTIC TK460

Mobil – 600 W Cylinder Oil

Shell – Sun Gear Oil 7C

2. To inspect FRONT #60 chain tension:

- Remove front cover plate.
- To adjust, loosen hex bolt with 3/4" wrench and rotate chain tensioner toward chain as shown until chain moves no more than a total of 1/4". See Figure 16 below.
- Grease chain periodically with a good quality MP grease.

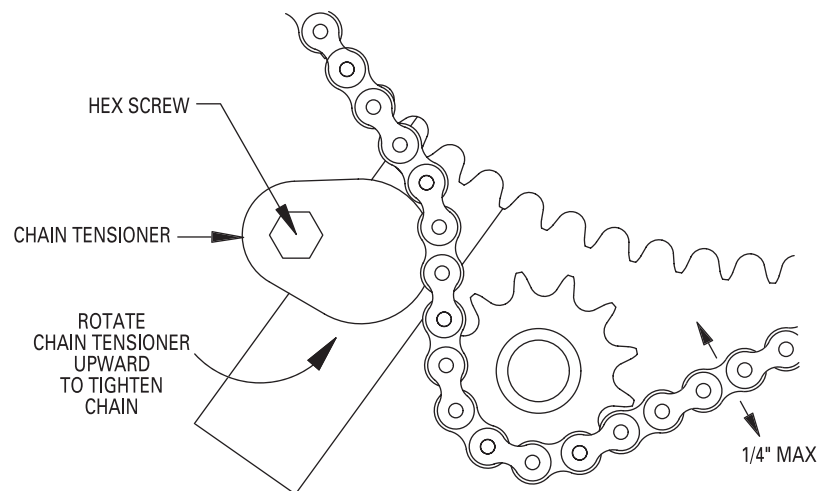

Figure 16

3. To inspect REAR #40 chain tension:

- Check chain tension after an initial break-in period of 2 - 3 hours of use and tighten per the instructions below. See Figure 17. Thereafter, inspect monthly.
- Remove the chain guard by taking out the 2 mounting screws.
- Loosen 8 bolts ( 4 on top and 4 on bottom ) that hold the gear box in position.
- To tighten chain, move the gear box to the left and re-tighten bolts.
- For correct tension, chain should deflect approximately 1/8" .

NOTE: Be sure to keep the gear box and motor in line with the bender.

- Grease chain periodically with a good quality MP grease.

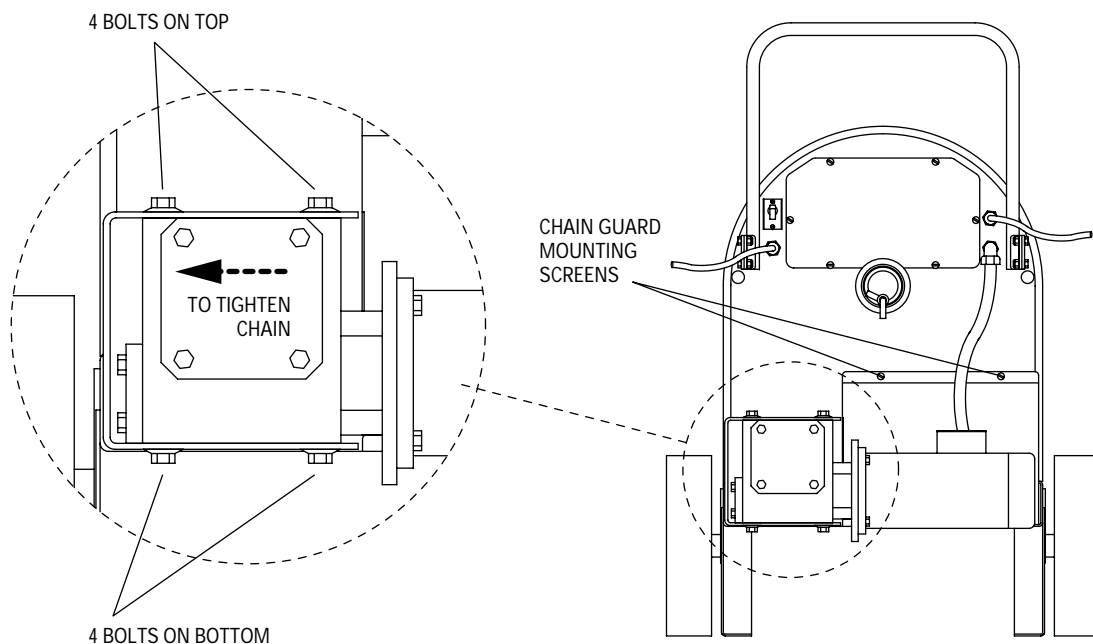

Figure 17



## STUB-UP BENDING INFORMATION AND CHARTS

To locate bending marks and springback of 15, 30, 45, 60, and 90 degree bends for a desired stub:

1. Check Chart A, B, or C for deduct length. Note that minimum stub length is deduct length plus 2".
2. Measure and mark desired stub length on conduit ( stub length mark ). Subtract "Deduct Length" from this mark and make a second mark ( bending mark ). See Fig 18a and 18b. Place bending mark at front edge of shoe hook. See Figure 18c. Check Chart A, B, or C for springback of desired degree of bend. Bender should be advanced to this degree to obtain desired degree of bend.

Figure 18a

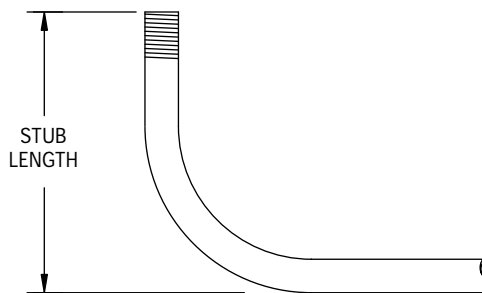

Figure 18b

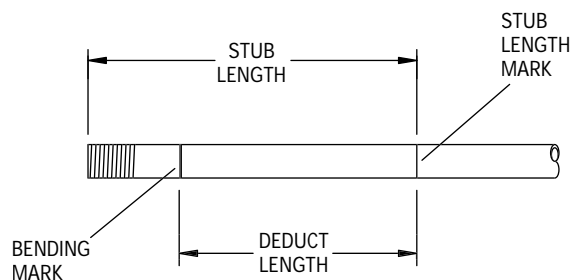
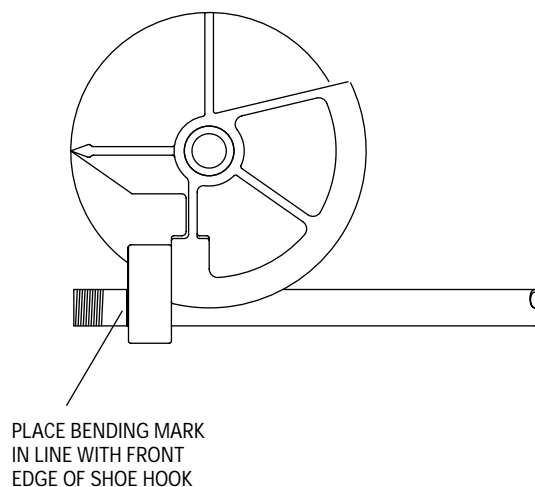

Figure 18c



### Chart A – RIGID Conduit/Schedule 40 Pipe

Conduit Size	Deduct Length	Springback				
		15°	30°	45°	60°	90°
1/2"	8 1/2"	20	36 1/4	51 1/4	67 1/2	97 1/2
3/4"	8 1/2"	16 1/4	31 1/4	46 1/4	61 1/4	92 1/2
1"	10"	17 1/2	32 1/2	47 1/2	63 3/4	93 3/4
1 1/4"	12 3/4"	17 1/2	32 1/2	47 1/2	63 3/4	95
1 1/2"	14 1/4"	18 3/4	33 3/4	48 3/4	65	95
2"	16 1/8"	20	35	48 3/4	63 3/4	96 1/4

### Chart B – EMT Conduit

Conduit Size	Deduct Length	Springback				
		15°	30°	45°	60°	90°
1/2"	7"	16 1/4	32 1/2	47 1/2	63 3/4	95
3/4"	8 7/8"	17 1/2	33 3/4	48 3/4	63 3/4	95
1"	10 3/4"	17 1/2	32 1/2	48 3/4	65	95
1 1/4"	13 1/8"	17 1/2	33 3/4	48 3/4	65	95
1 1/2"	13 7/8"	16 1/4	31 1/4	46 1/4	61 1/4	92 1/2
2"	15 3/8"	17 1/2	33 3/4	48 3/4	63 3/4	95



### Chart C – IMC Conduit

Conduit Size	Deduct Length	Springback				
		15°	30°	45°	60°	90°
1/2"	8 1/2"	21 1/4	37 1/2	52 1/2	68 3/4	98 3/4
3/4"	8 1/2"	17 1/2	32 1/2	47 1/2	63 3/4	93 3/4
1"	10"	17 1/2	32 1/2	47 1/2	63 3/4	95
1 1/4"	12 3/4"	18 3/4	33 3/4	48 3/4	65	96 1/4
1 1/2"	13 3/4"	17 1/2	33 3/4	48 3/4	63 3/4	95
2"	15 1/4"	20	35	50	65	96 1/4

[www.TradeToolSupply.com](http://www.TradeToolSupply.com)  
 503.221.8665  
 Sales and Rentals

NOTE: Springback figures are approximate.

Minimum Stub Length = Deduct Length plus 2"



## OFFSET BENDING INFORMATION AND CHARTS

To locate bending marks for a desired offset:

1. Measure distance from end of conduit to start of bend and mark conduit. ( Mark 1 ) See Figure 19b.
2. Refer to chart E for measurement "X" and deduct this distance from Mark 1 and place Mark 2 on conduit. See page 23.
3. Refer to chart D for center-to-center distance between marks. Measure this distance from Mark 2 and place Mark 3 on conduit.
4. Layout of bends is now complete. Next, place Mark 2 in line with front edge of shoe hook and make first bend. See Figure 19c.
5. Rotate conduit 180 degrees. Place Mark 3 in line with front edge of shoe hook and complete second bend.

Figure 19a

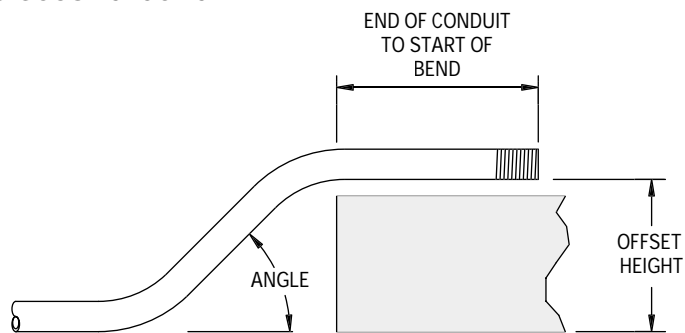
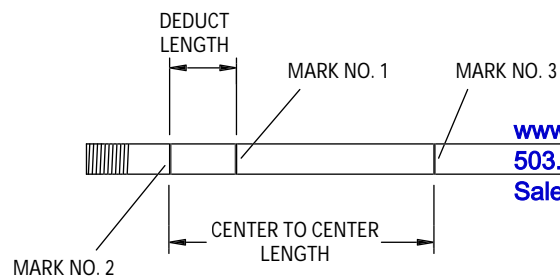
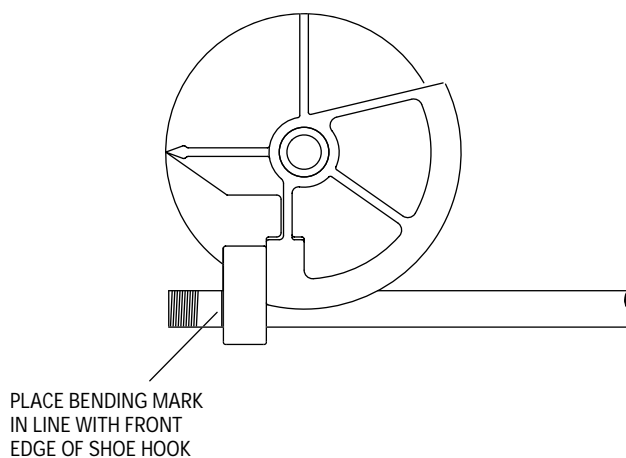

Figure 19b



[www.TradeToolSupply.com](http://www.TradeToolSupply.com)  
503.221.8665  
Sales and Rentals

Figure 19c



**Chart D – Offset Height** *Figures are approximate.*

Offset Height		2	4	6	8	10	12	14	16	18	20	22
15°	Max Conduit Size	3/4"	1 1/2"	2"	2" and smaller							
	Center-to-Center	7 3/4"	15 7/16"	23 3/16"	30 15/16"	38 5/8"	46 3/8"	54 1/16"	61 13/16"	69 9/16"	77 1/4"	85"
30°	Max Conduit Size		3/4"	1"	1 1/2"	2"	2" and smaller					
	Center-to-Center		8"	12"	16"	20"	24"	28"	32"	36"	40"	44"
45°	Max Conduit Size			1/2"	1"	1 1/4"	1 1/2"	2"	2" and smaller			
	Center-to-Center			8 1/2"	11 5/16"	14 1/8"	16 15/16"	19 13/16"	22 5/8"	25 7/16"	28 1/4"	31 1/8"

To locate center-to-center distance of offset bending marks other than those listed in Chart D, use the following multipliers. Multiply the height of offset desired by 3.86 on 15 degree bends, 2 on 30 degree bends, and 1.4 on 45 degree bends.

**Chart E** *Figures are approximate.*

Conduit Size	1/2	3/4	1	1 1/4	1 1/2	2
"x"	3 1/16"	3 1/16"	3 1/16"	4"	4 1/4"	4 1/2"



**TRADE TOOL**

[WWW.TRADETOOLSUPPLY.COM](http://WWW.TRADETOOLSUPPLY.COM)

503.221.8665

Sales and Rentals Available

# ! WARNING

**ALWAYS** disconnect power supply before removing any guards or covers and before servicing this bender. Failure to do so may result in serious injury or death.

Problem	Cause	Diagnosis	Cure
1. Bender will not operate	Power source	Check for voltage at power source	If power is on, go to (#3)
2. No power at bender	Bad power cord	Ohm cord for broken wire	Replace cord
3. Power to bender but will not operate	Circuit breaker / power switch in the off position	Check power on load side of breaker to neutral with volt meter	Turn circuit breaker on. If on, go to next step.
	Fuse #1 blown	Ohm circuit for short	Replace
	Control Transformer bad	Check voltage in and out, if input but no output	Replace
	Contactors bad	Check contacts and ohm coil for open circuit	Replace
	Bridge rectifier bad	Check with ohm meter	Replace
	Switch bad Motor bad	Check with ohm meter Check brushes and ohm for open or short armature	Replace Replace
4. Motor runs but will not bend	Chain from gear box to jack shaft broken	Remove cover and visually check for broken parts	Replace
	Bad gear box	Motor running but no output through gear box	Replace
	Chain from jack shaft to shoe sprocket broken	Remove cover and visually check for broken parts	Replace
	Key between motor and gear box missing	Remove motor from gear box	Replace key
5. Bender operates in one direction only	Bad FWD / REV switch	Ohm switch for open contact or shorted contacts	Replace
	Bad pendant cord	Ohm for broken wire	Replace
	Bad contactor	Check contacts and ohm coil for open circuit	Replace
6. Contactors chatter	Low power to bender	Check with amp meter	Do not use long drop cords